

# Catalogue

安徽千航新能源科技有限公司

Anhui Qianhang New Energy Technology Co.,Ltd

诚信铸就品质 创新引领未来

Honesty Casts Quality Innovation and Leads the Future



## Anhui Qianhang New Energy Technology Co.,Ltd Company brief introduction

Anhui Qianhang New Energy Technology Company Limited established in the year 2015, which is a professional manufacturer specializing in the production, research and development, design, and trading of lithium battery. We locate in Bengbu City, enjoy convenient transportation access to vital port Shanghai. Our well-equipped facilities and strict quality control throughout all stages of production enables us to guarantee total customer satisfaction. Our products comply with international quality standards and are appreciated in a variety of different markets throughout the world.

We have employees, more than a dozen technical personnel. Our exported percentage occupies around 50%. Our well-equipped facilities and excellent quality control throughout all stages of production enables us to guarantee total customer satisfaction. Qianhang won the reputation of “new high-tech enterprise” in 2019 and came to terms with Chinese electrical science & technology group company on strategic co-work agreement to exploit abroad markets.

As a result of our reliable products and professional customer service, we have saled our products to Indonesia, Holland and other country. We have our-own and international universal certificate of the system of QC. If you are interested in any item of our products or would like to make deals with Qianhang, please feel free to contact us. We are looking forward to building a friendly cooperation with new clients around the world in the near future.



# CONTENTS

# 目录



**Industrial Battery**



**Special Battery**



**Energy storage**

# Sweeping power

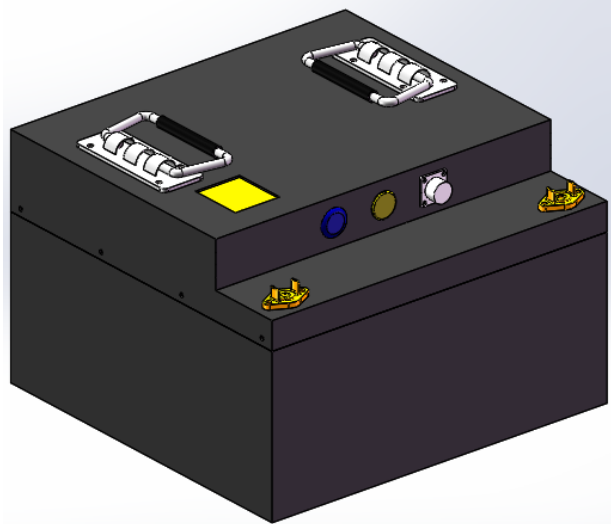

Model	QH25. 6V84Ah0596	Volt Arrange	20V-29. 2V
Rated Volt	25. 6V	Rated Capacity	84Ah
discharge current	84A	Discharge Temperature	-20°C-60°C
Charge current	30A	charge Temperature	-0°C-45°C
Size	340*325*222mm	weight	around 26kg
Communication	Real-time monitor	Service life	5Y

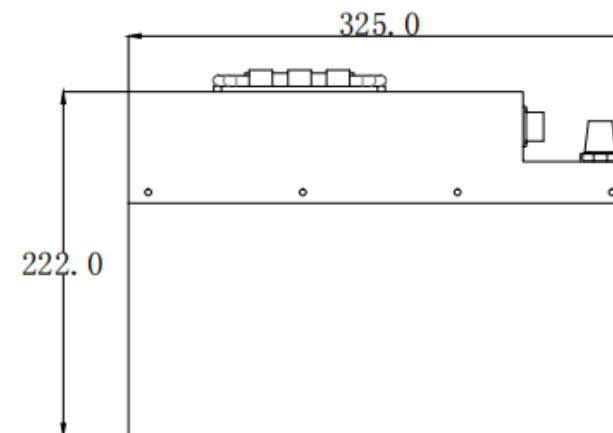
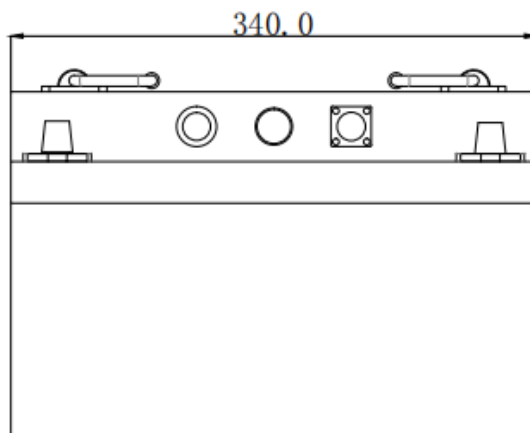
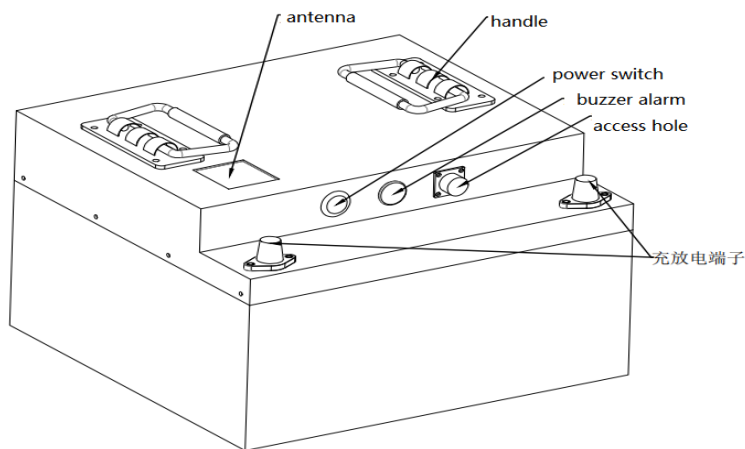

# Recreational vehicle

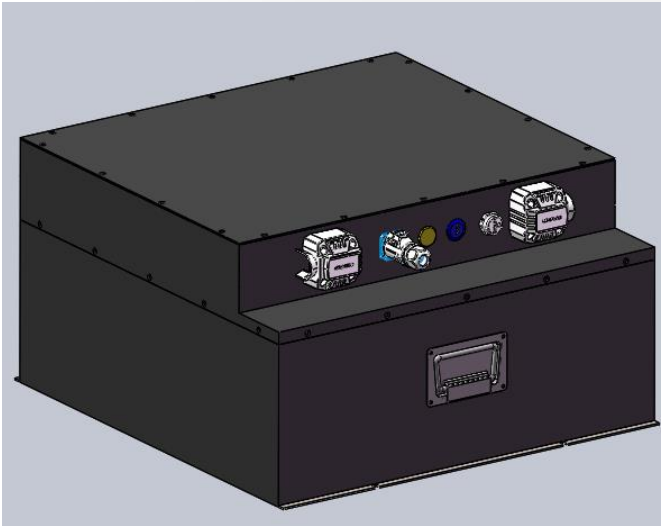

battery model	QH12.8V824Ah0636	volt arrange	10.8V-14.6V
rated volt	12.8V	rated capacity	824Ah
discharge current	200A	discharge temperature	-20°C-60°C
charge current	100A	charge temperature	-0°C-45°C
size	540*520*295mm	weight	around85kg
communication	CAN	service life	5Y
screen	EA4.3inch screen	parallel	parallel under same model

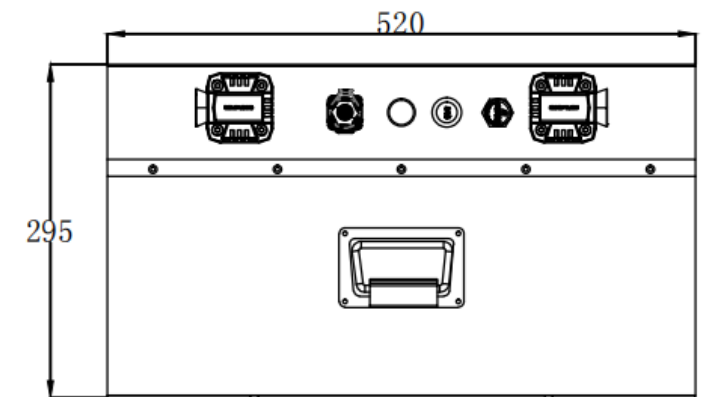
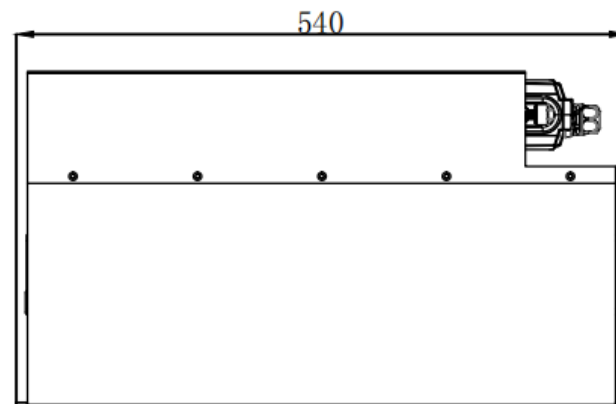
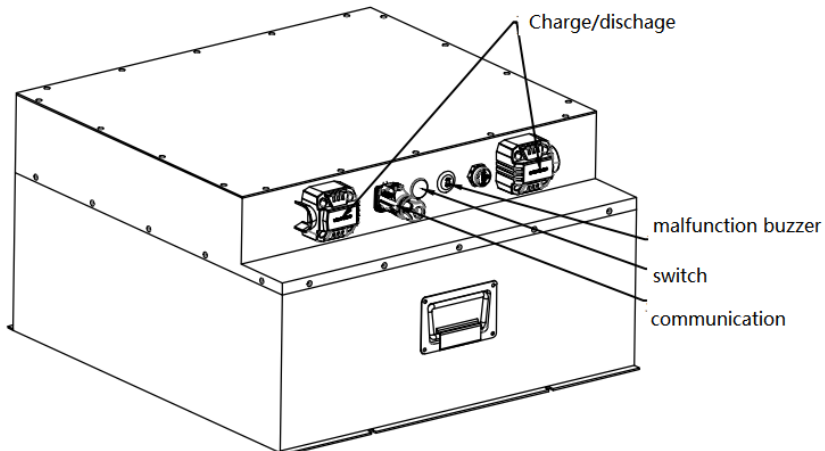

# recreational vehicle

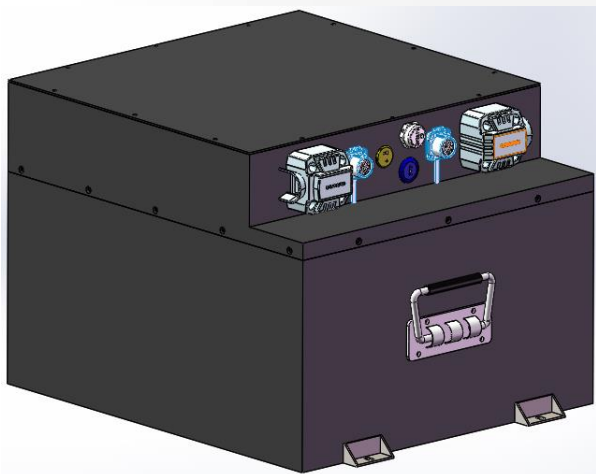

model	QH12.8V618Ah0778	volt arrange	10.8V-14.6V
rated volt	12.8V	rated capacity	618Ah
discharge current	200A	discharge temperature	-20°C-60°C
charge current	100A	charge temperature	-0°C-45°C
size	480*390*315mm	weight	around73kg
communication	CAN	service life	5Y
screen	EA4.3inch screen	parallel	parallel under same model

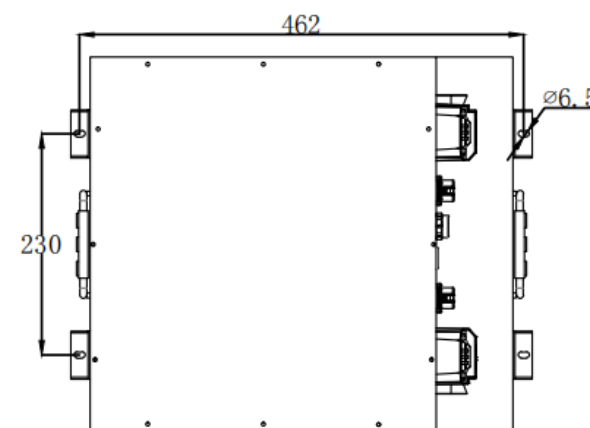
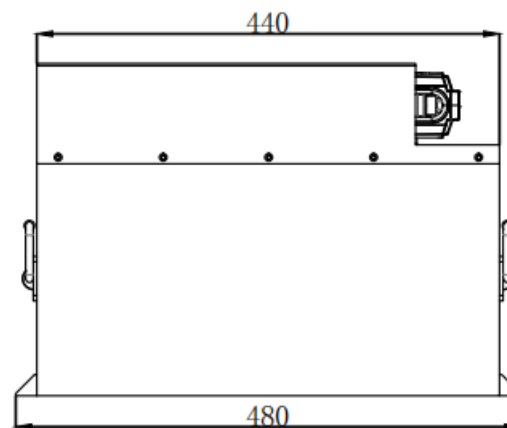
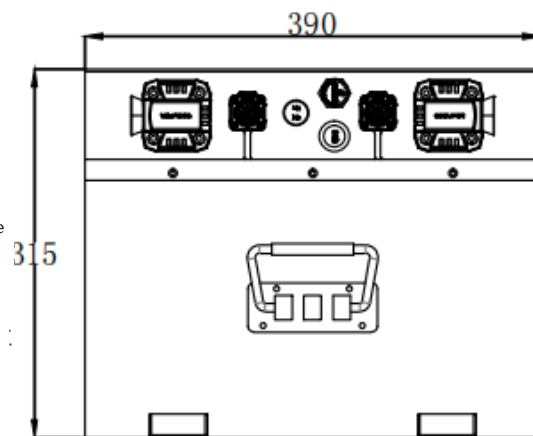
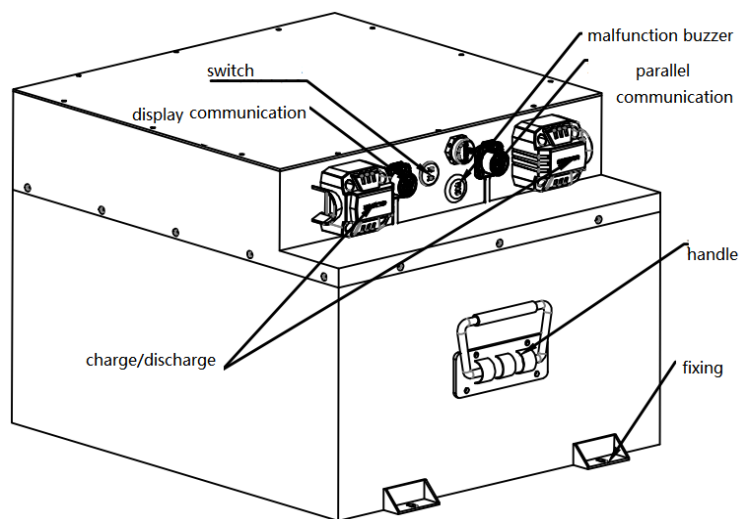

# rv vehcile

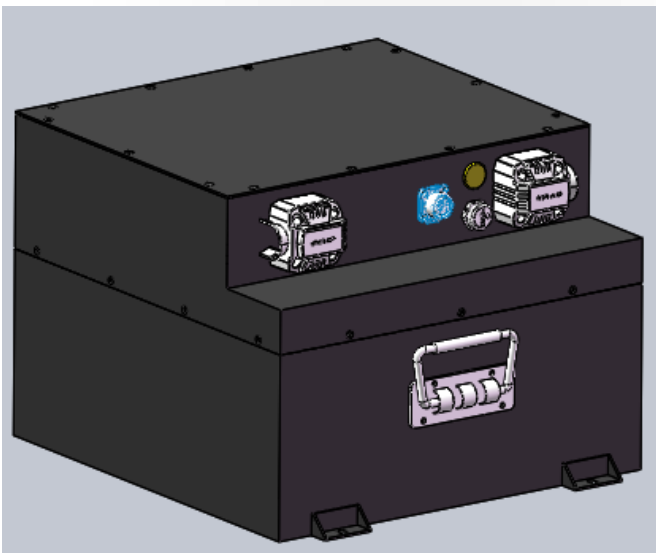

model	QH12.8V412Ah0783	volt arrange	10.8V-14.6V
rated volt	12.8V	rated capacity	412Ah
discharge current	200A	discharge temperature	-20°C-60°C
charge current	100A	charge temperature	-0°C-45°C
size	436*390*295mm	weight	around80kg
communicaition	CAN	service life	5Y
screen	EA4.3inch screen	parallel	parallel under same model

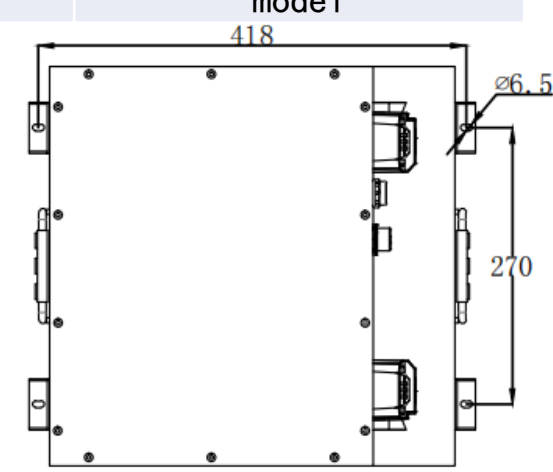
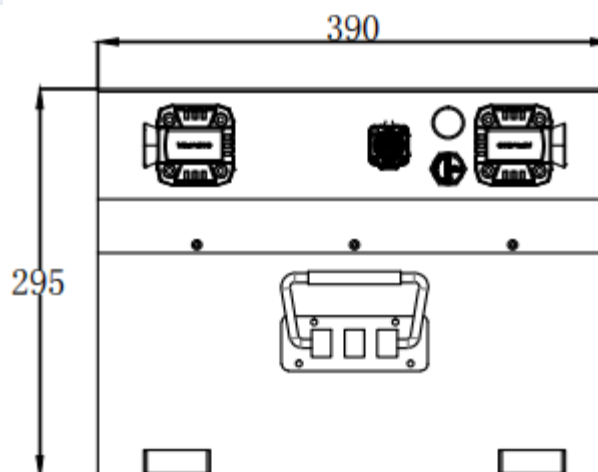
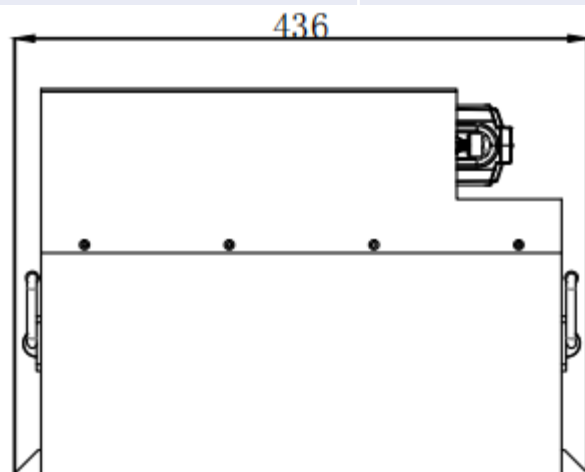
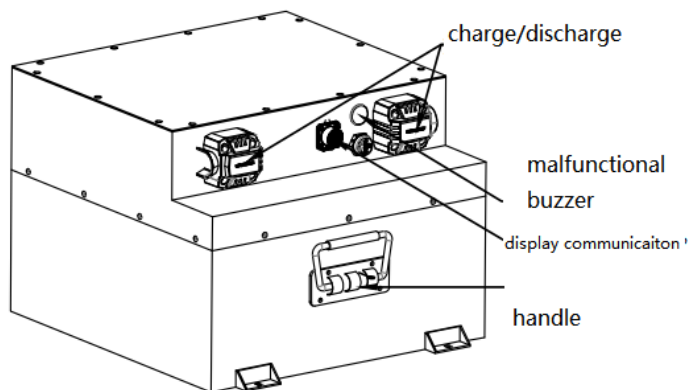

# rv vehicle

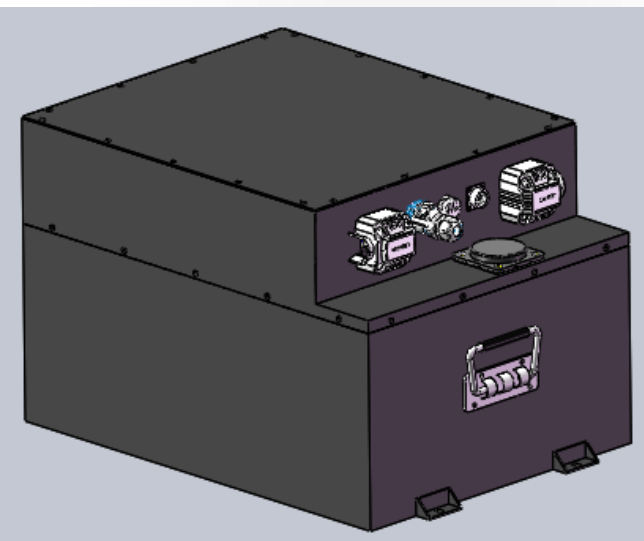

model	QH51.2V206Ah0721	volt arrange	40V-58.4V
rated volt	51.2V	rated capacity	206Ah
discharge current	150A	discharge temperature	-20°C-60°C
charge current	100A	charge temperature	-0°C-45°C
size	570*400*350mm	weight	around85kg
communication	CAN	service life	5Y
screen	EA4.3inch screen	parallel	parallel under same model

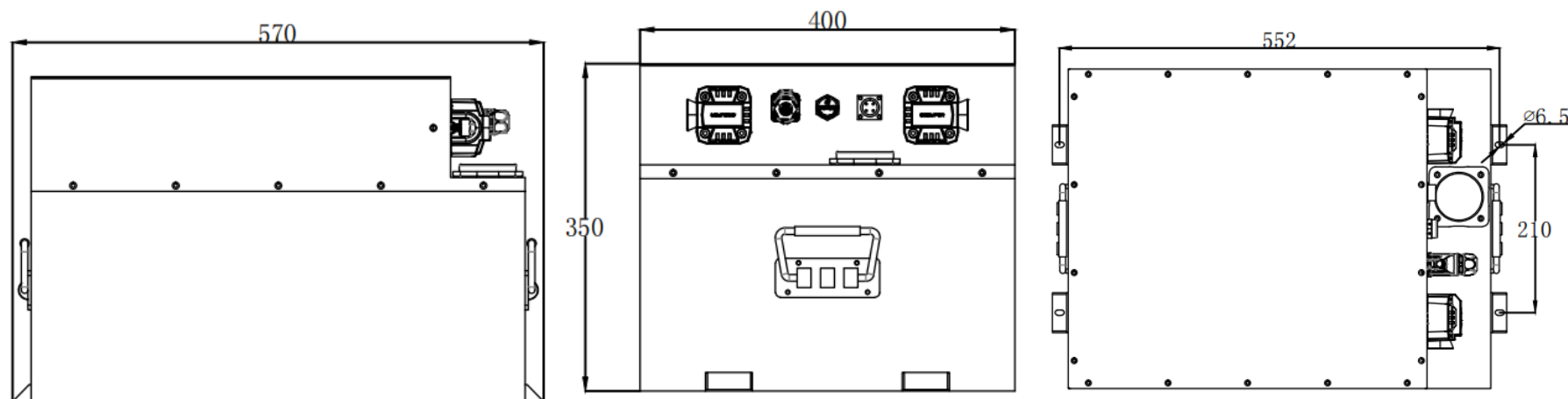
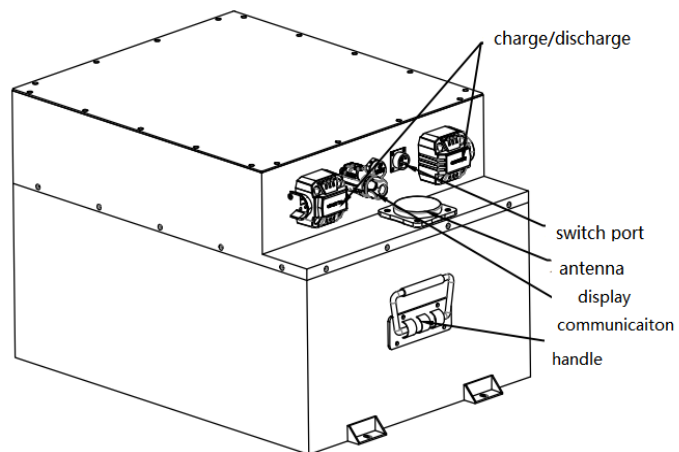



# trailer power

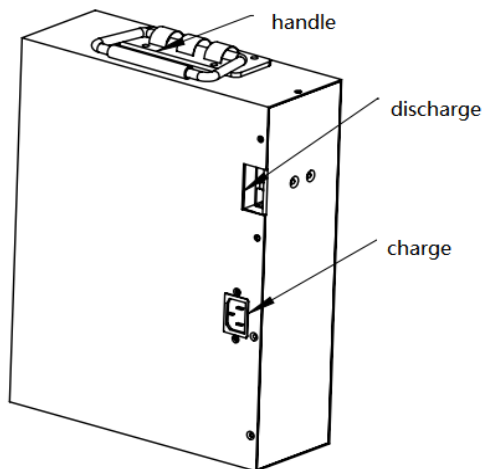
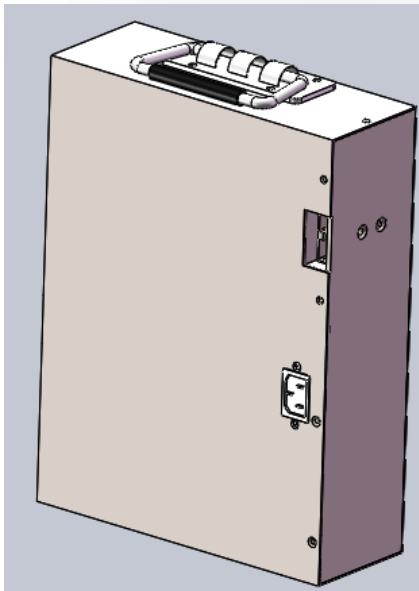

model	QH48V12Ah0203	volt arrange	37.5V-54.75V
rated volt	48V	rated capacity	12Ah
discharge current	15A	discharge temperature	-20°C-60°C
charge current	3A	charge temperature	-0°C-45°C
size	224*85*295mm	weight	6kg
material	stainless steel	service life	3Y
charge hole	top and twin-side	discharge hole	50A anderson

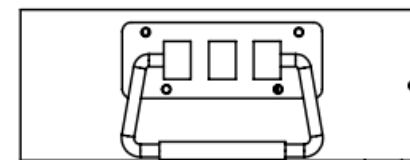
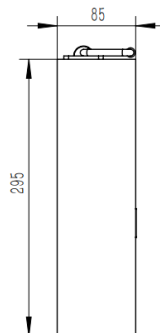
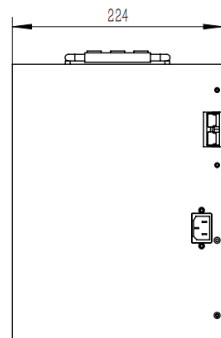

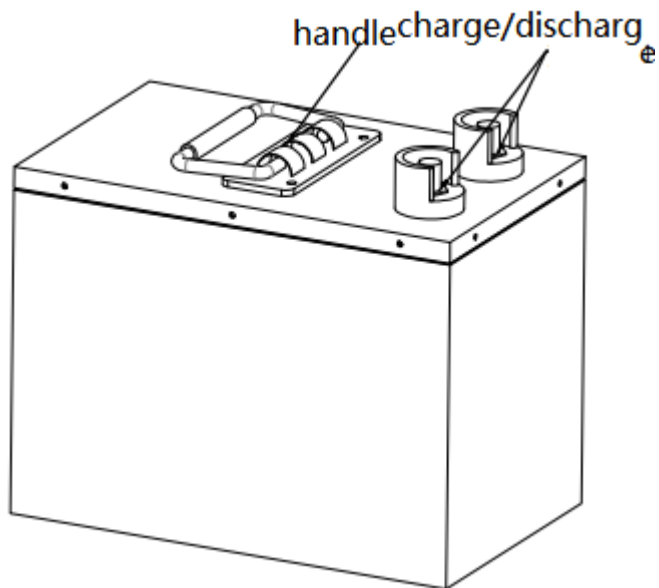
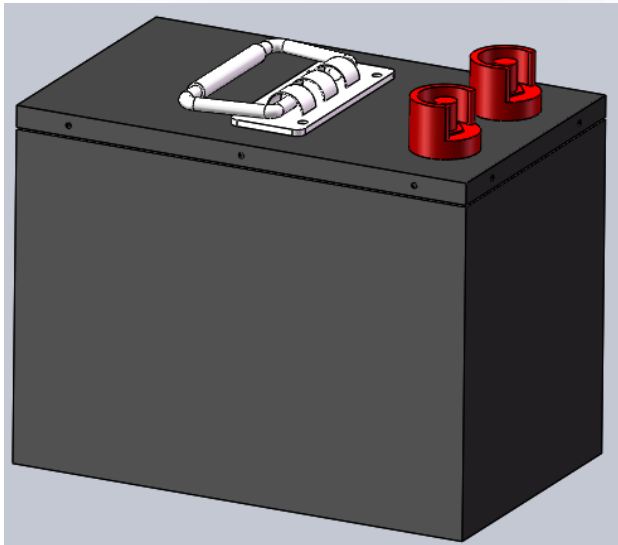

model	QH25. 6V42Ah0142	volt arrange	20V-29. 2V
rated volt	25. 6V	rated capacity	42Ah
discharge current	40A	discharge temperature	-20°C-60°C
charge current	10A	charge temperature	-0°C-45°C
size	260*160*195mm	weight	73kg
communication	no	service life	3Y
screen	no		

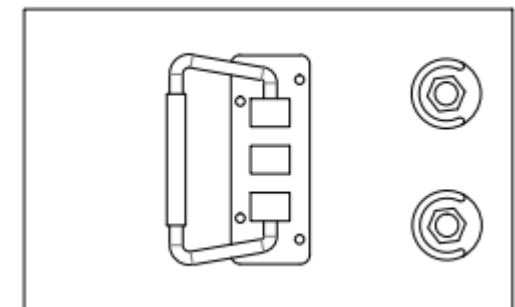
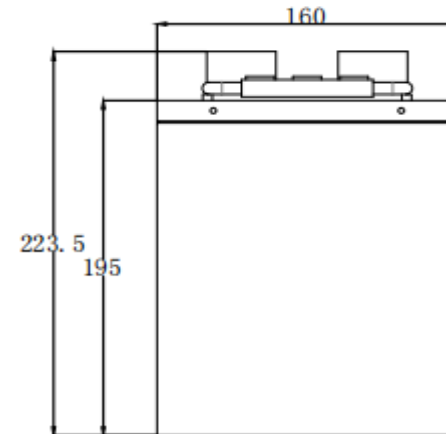
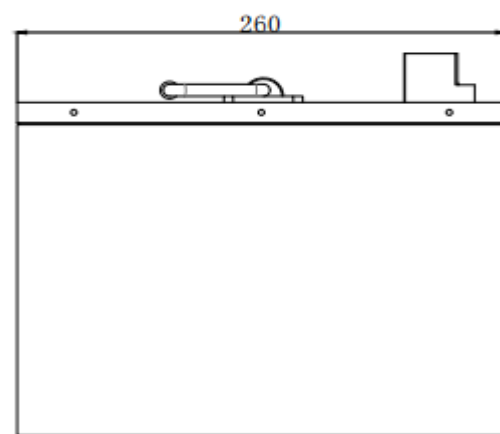

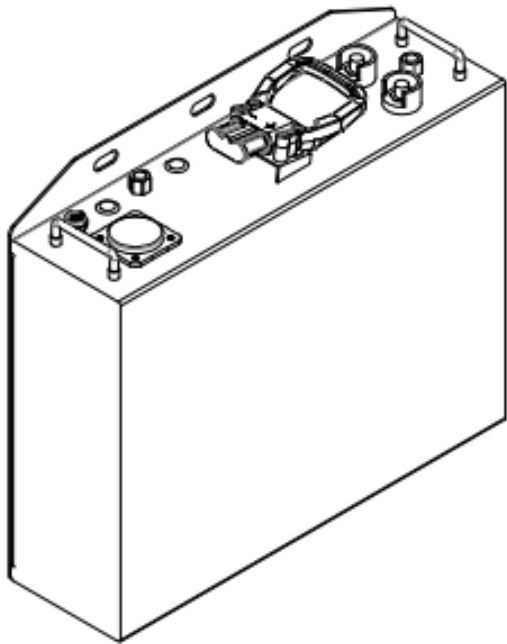

model	QH25.6V150Ah0331	volt arrange	20V-29.2V
rated volt	25.6V	rated capacity	200Ah
discharge current	150A	discharge temperature	-20°C-60°C
charge current	50A	charge temperature	-0°C-45°C
size	595*173*510mm	weight	60kg
communication	CAN, real time monitor	service life	5Y
screen	round meter		

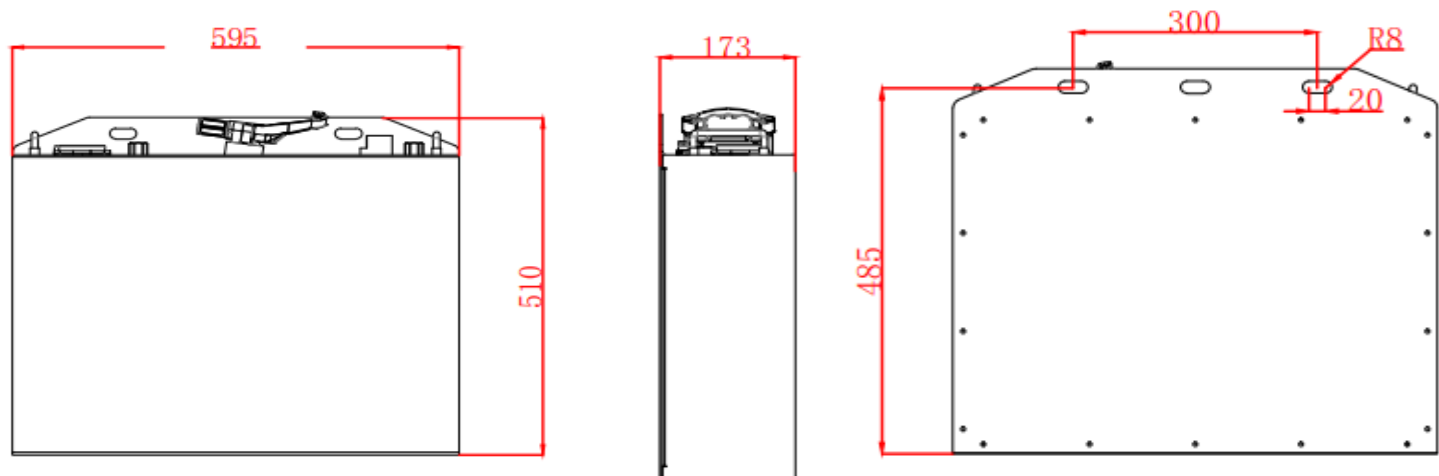
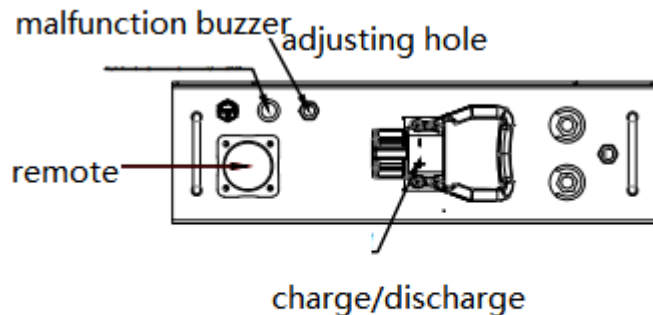

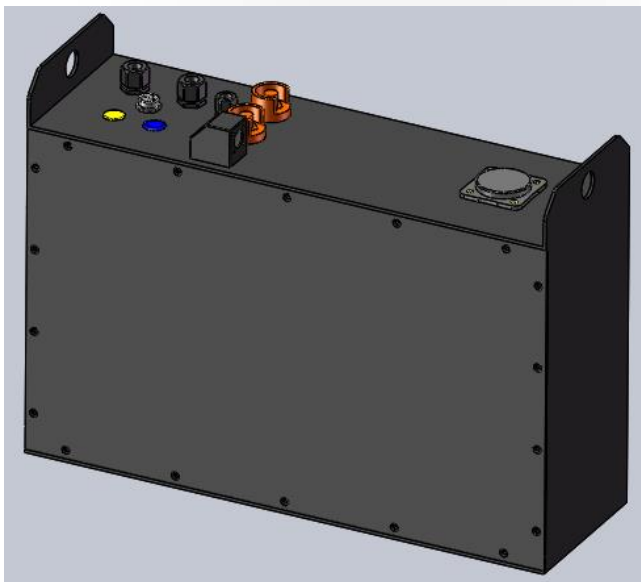

model	QH25.6V150Ah0138	volt arrange	20V-29.2V
rated volt	25.6V	rated capacity	200Ah
discharge current	150A	discharge temperature	-20°C-60°C
charge current	50A	charge temperature	-0°C-45°C
size	640*200*460mm	weight	60kg
communication	CAN, real time monitor	service life	5Y
screen	round meter	charge/dischargehole	separated

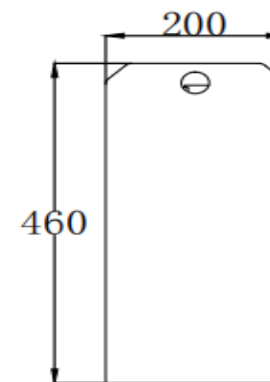
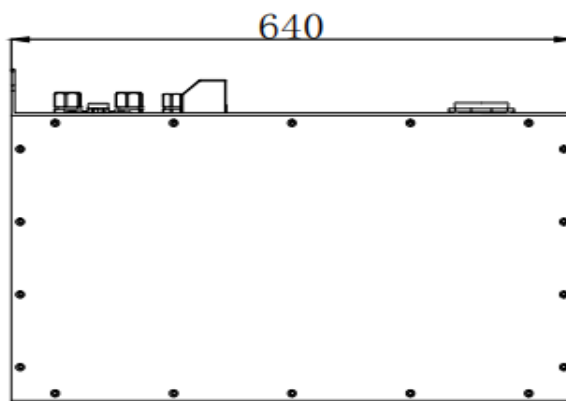
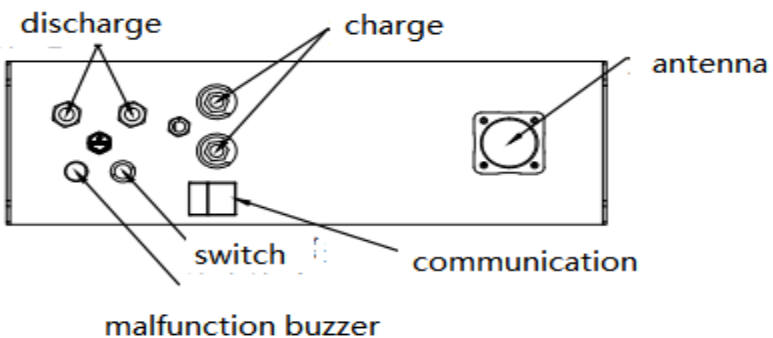

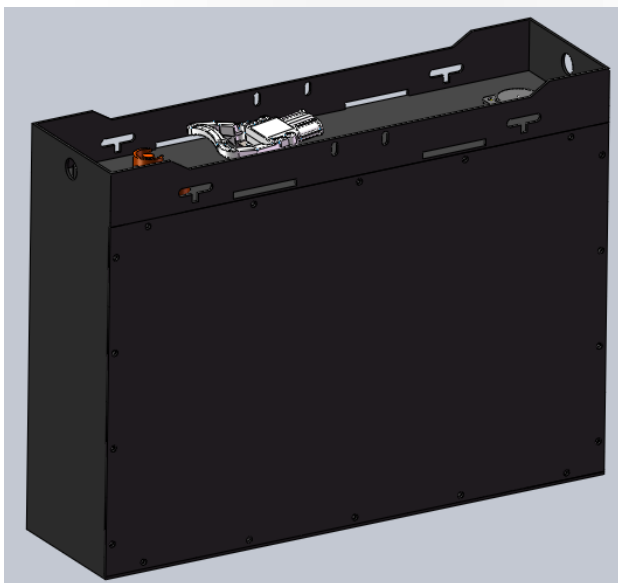

model	QH25.6V200Ah0362	rated volt	20V-29.2V
rated volt	25.6V	rated capacity	200Ah
discharge current	100A	discharge temperature	-20°C-60°C
charge current	100A	charge temperature	-0°C-45°C
size	790*210*595mm	weight	72kg
communication	CAN, real time monitor	service life	5Y
screen	round meter		

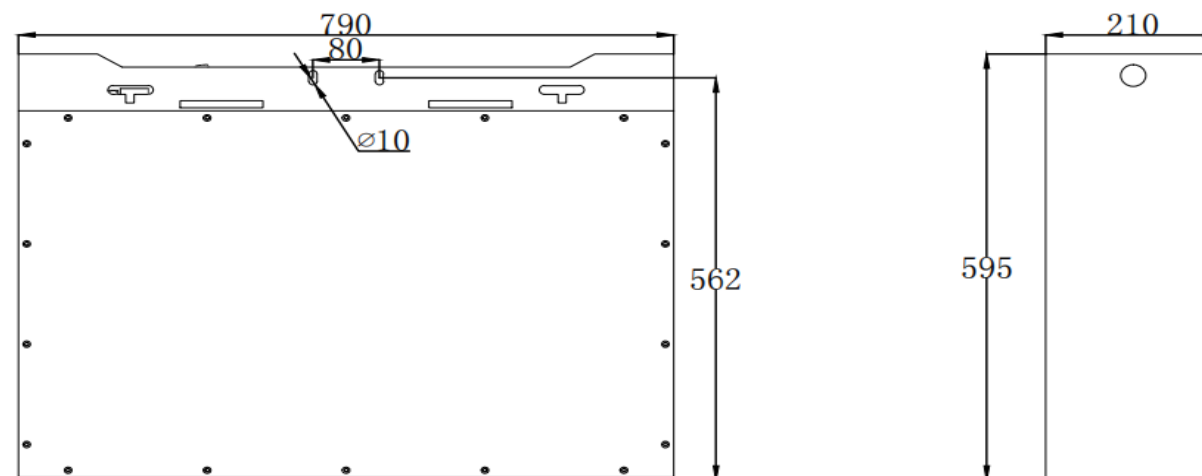
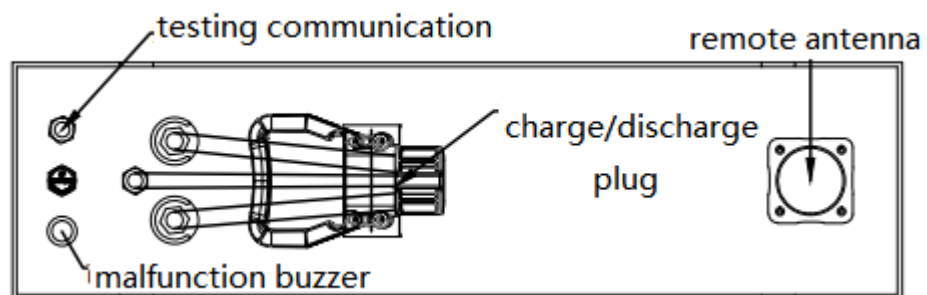

moving  
power

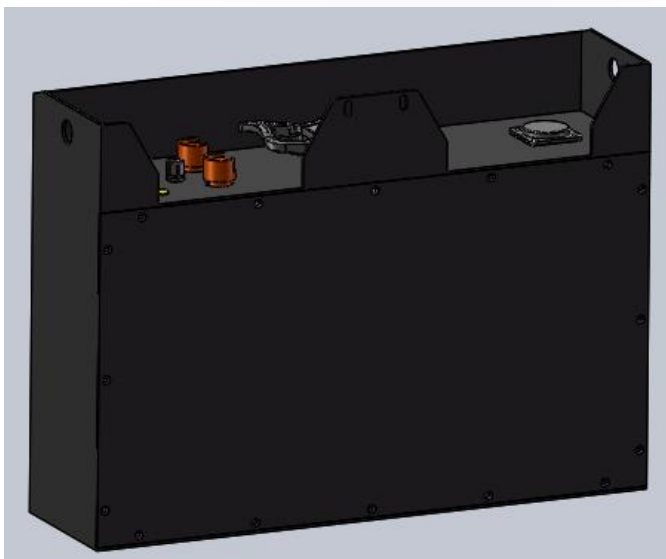

model	QH25. 6V200Ah001	rated volt	20V-29. 2V
rated volt	25. 6V	rated capacity	200Ah
discharge current	100A	discharge temperature	-20°C-60°C
charge current	100A	charge temperature	-0°C-45°C
size	790*210*575mm	weight	72kg
communication	CAN, real time monitor	service life	5Y
screen	round meter		

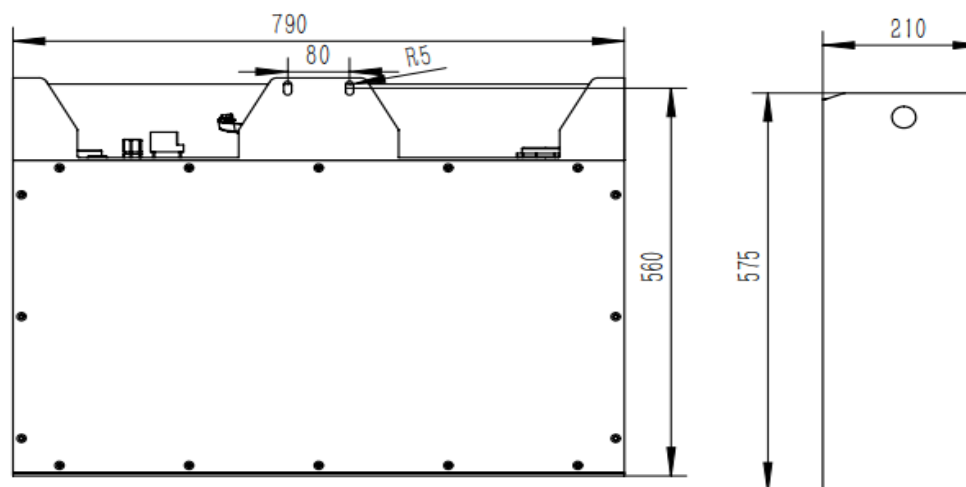
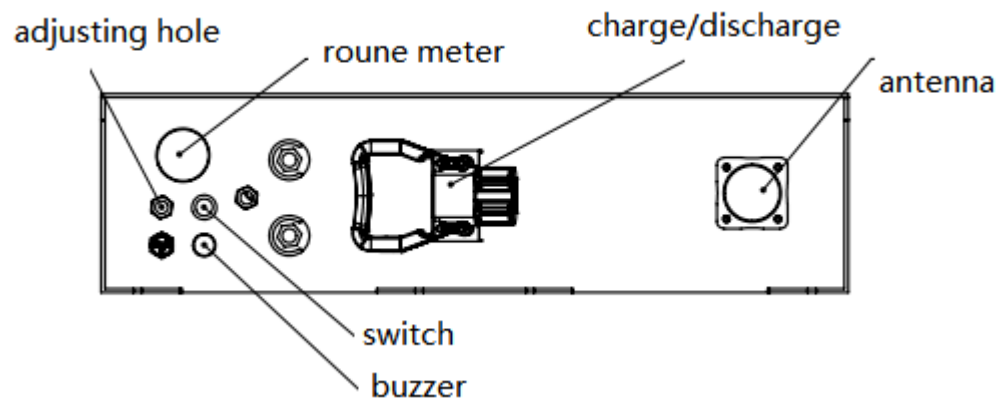

# moving cart power

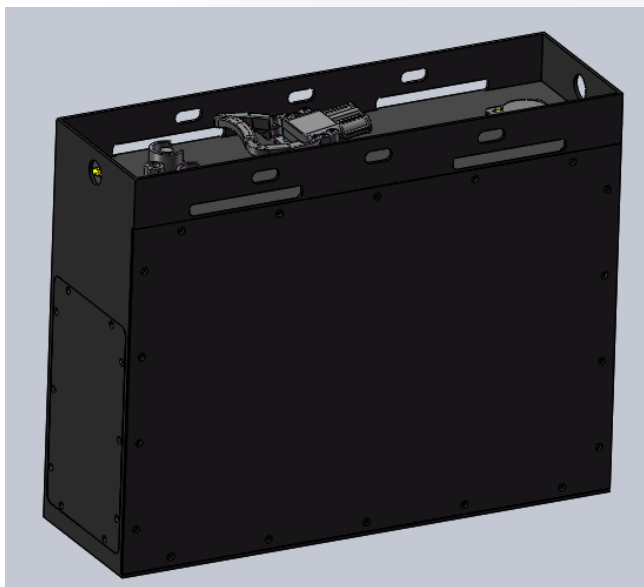

model	QH25. 6V200Ah0448		volt arrange	20V-29. 2V
rated volt	25. 6V	rated capacity	200Ah	
discharge current	100A	discharge temperature	-20°C-60°C	
charge current	100A	charge temperature	-0°C-45°C	
size	648*200*510mm	weight	72kg	
communication	CAN, real time monitor	service life	5Y	
screen	round meter			

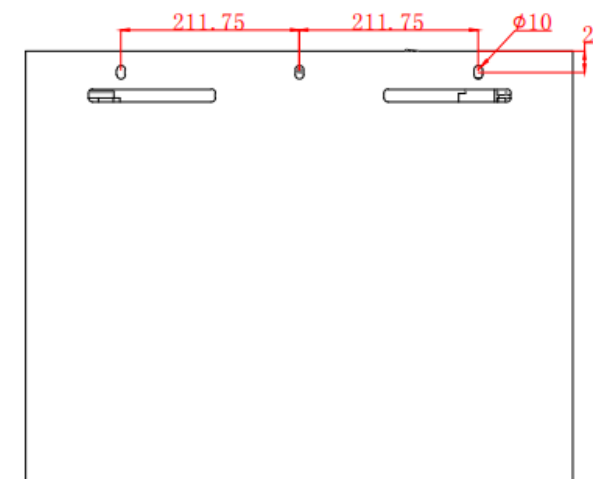
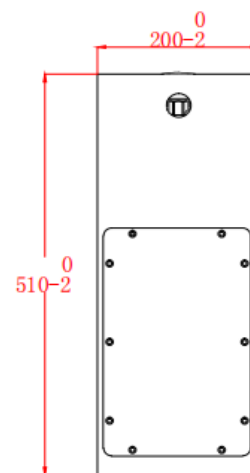
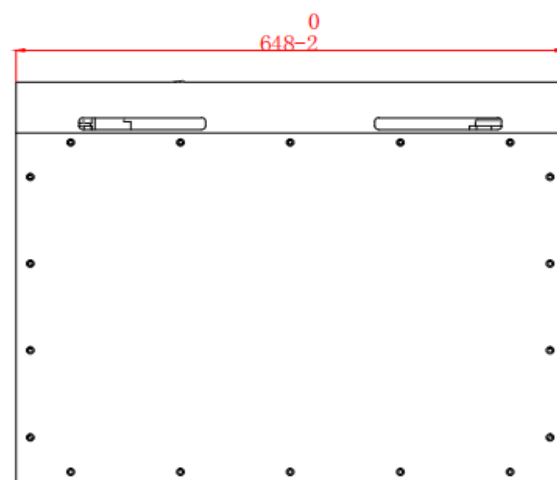
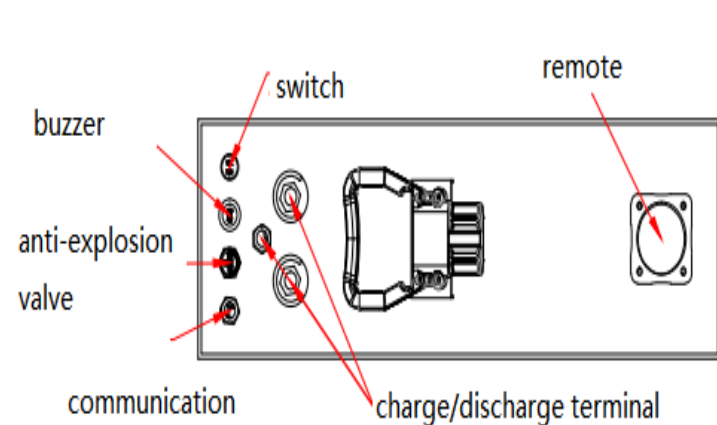

# moving cart power

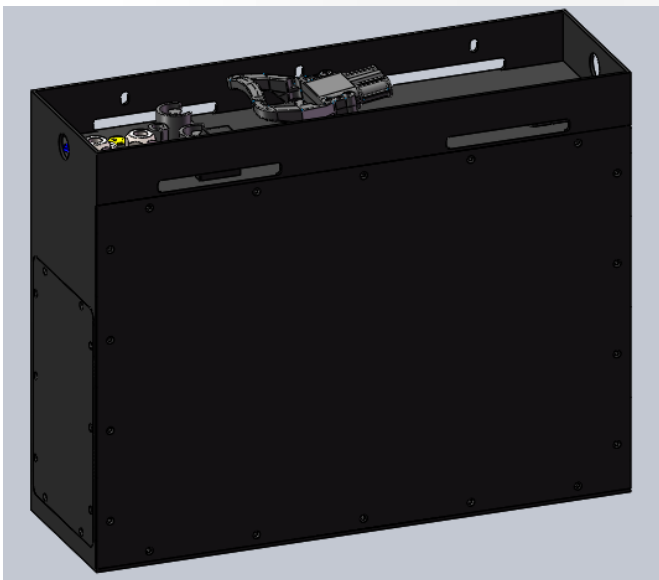

model	QH25. 6V200Ah0449	volt arrange	20V-29. 2V
rated volt	25. 6V	rated capacity	200Ah
discharge current	100A	discharge temperature	-20°C-60°C
charge current	100A	charge temperature	-0°C-45°C
size	648*200*510mm	weight	72kg
communication	CAN, real time monitor	service life	5Y
screen	round meter	rated capacity	separated

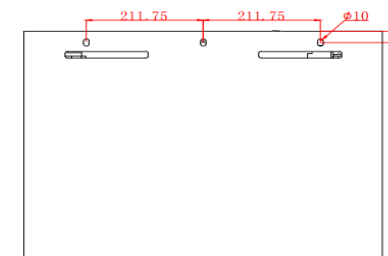
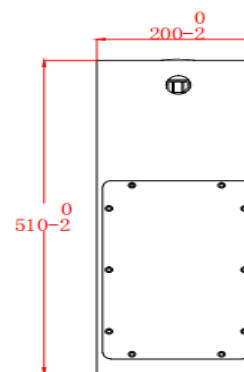
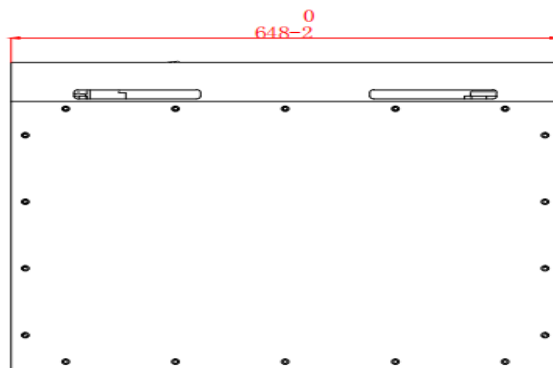
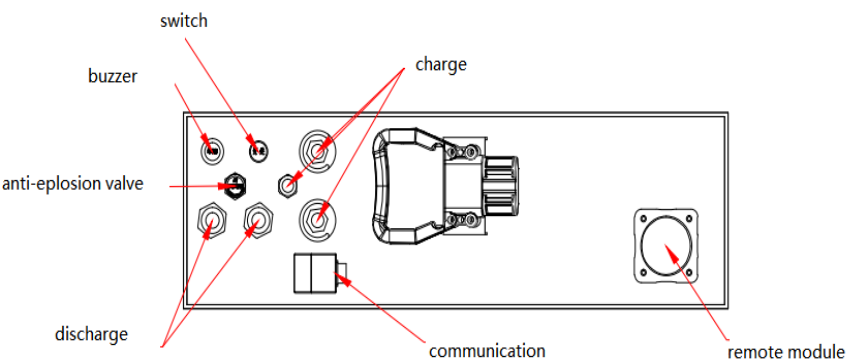



# counter balanced forklift

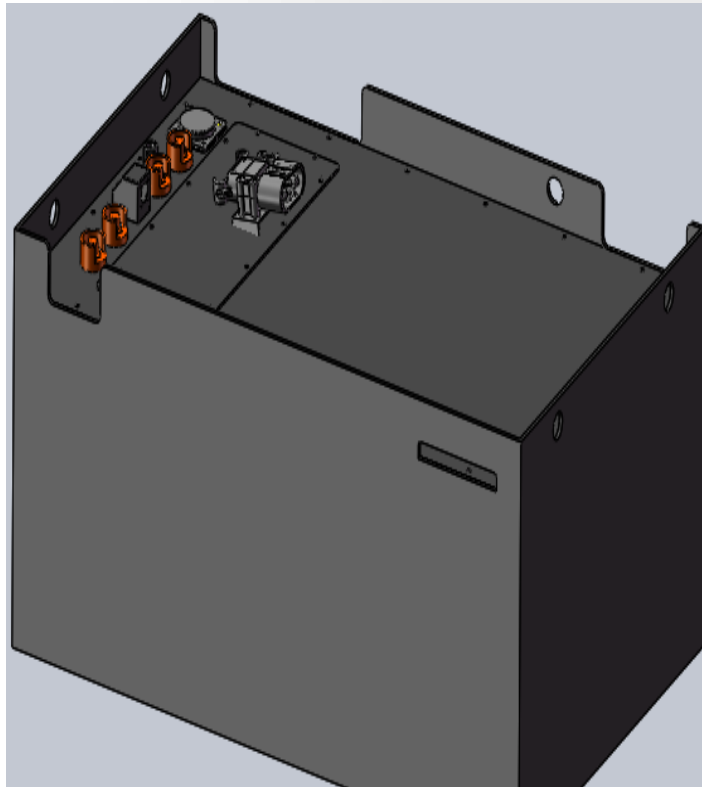

case vehicle	lizhiyou FB15P		
model	QH48V450Ah0798	volt arrange	37.5V-54.75V
rated volt	48V	rated capacity	450Ah
discharge current	200A	discharge temperature	-20°C-60°C
charge current	200A	charge temperature	-0°C-45°C
size	970*600*470mm	weight	640kg (extra weight included)
communication	CAN, real time monitor	service life	5Y
screen	EV4.3inch	charge/discharge	separated

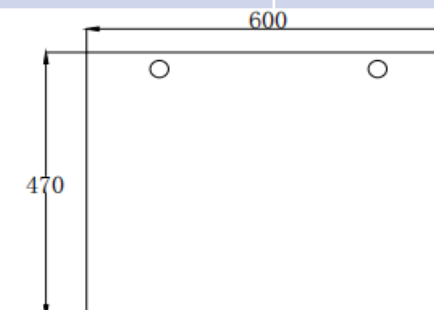
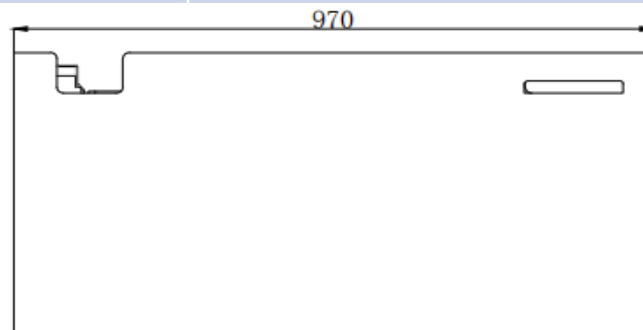
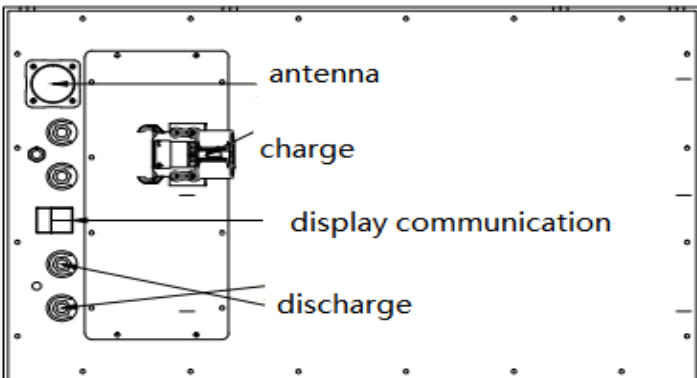

# counter balanced forklift

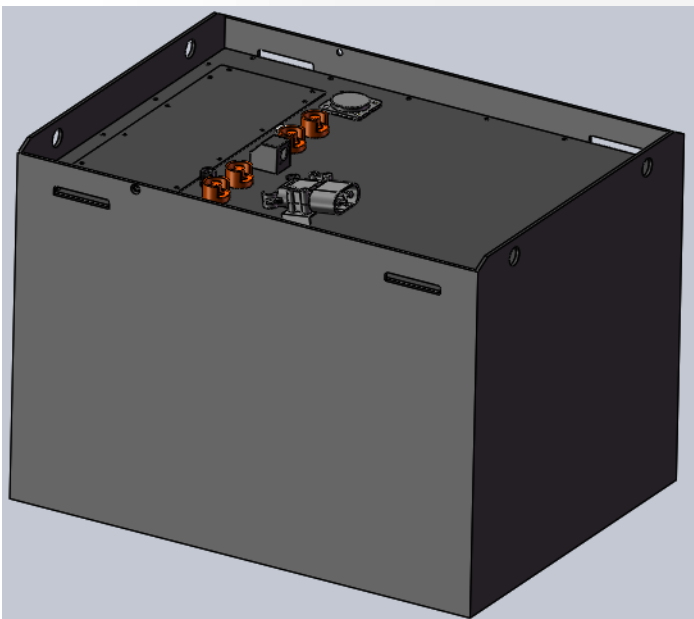

case vehicle	lindeE16C		
model	QH51.2V400Ah0524	volt arrange	40V-58.4V
rated volt	51.2V	rated capacity	400Ah
discharge current	200A	discharge temperature	-20°C-60°C
charge current	200A	charge temperature	-0°C-45°C
size	827*627*600mm	weight	850kg (extra weight include)
communication	CAN, real time monitor	service life	5Y
screen	EV4.3inch	charge/discharge	separated

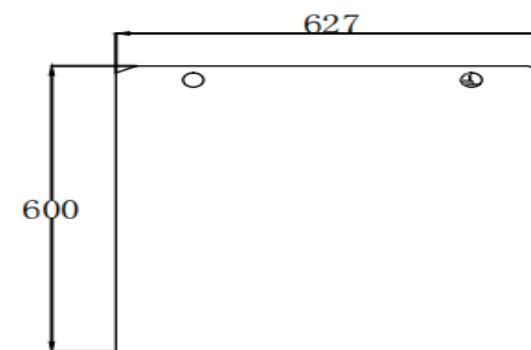
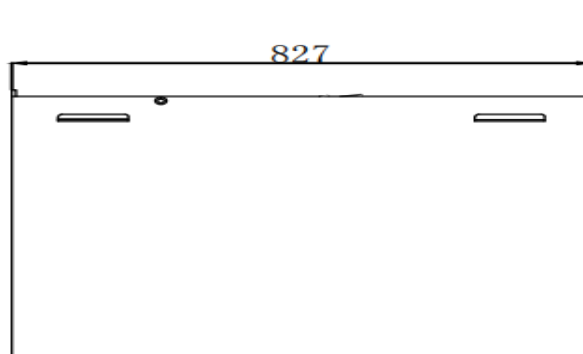
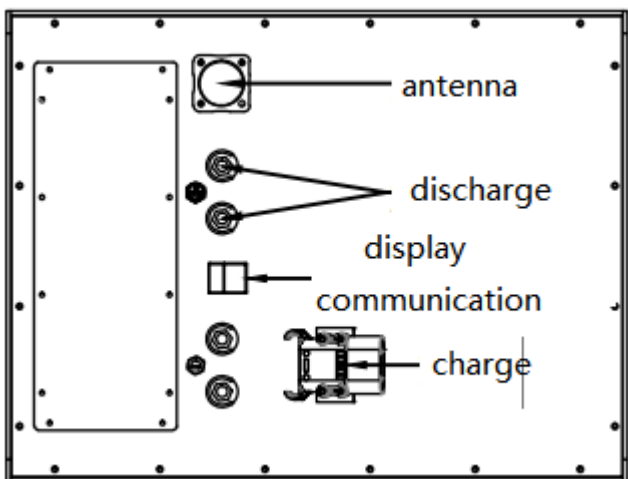

# counter balanced forklift

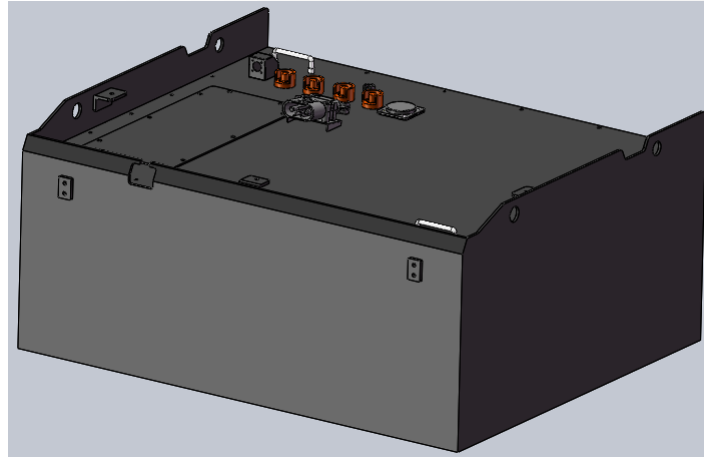

case vehicle	toyotaFB30		
model	QH76. 8V300Ah0328	volt arrange	60V-87. 6V
rated volt	76. 8V	rated capacity	300Ah
discharge current	200A	discharge temperature	-20°C-60°C
charge current	150A	charge temperature	-0°C-45°C
size	827*627*600mm	weight	1100kg (extra weight included)
communication	CAN, real time monitor	service life	5Y
screen	EV4. 3inch	charge/discharge	separated

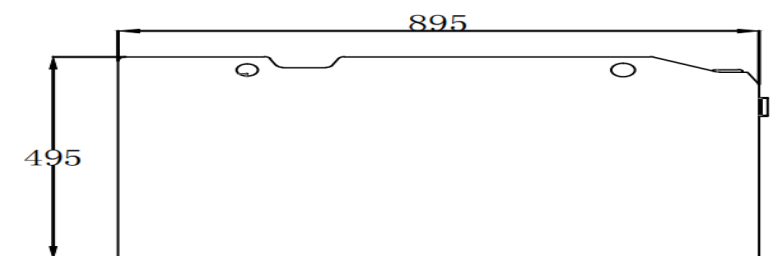
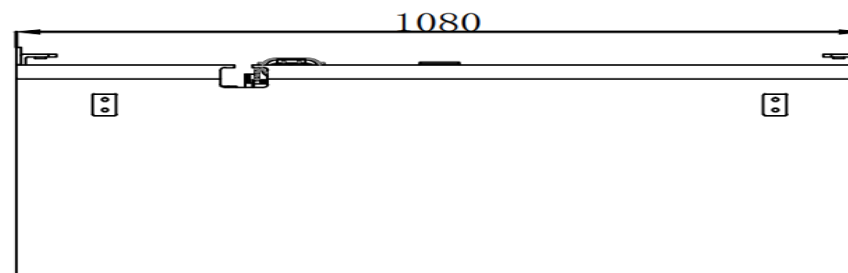
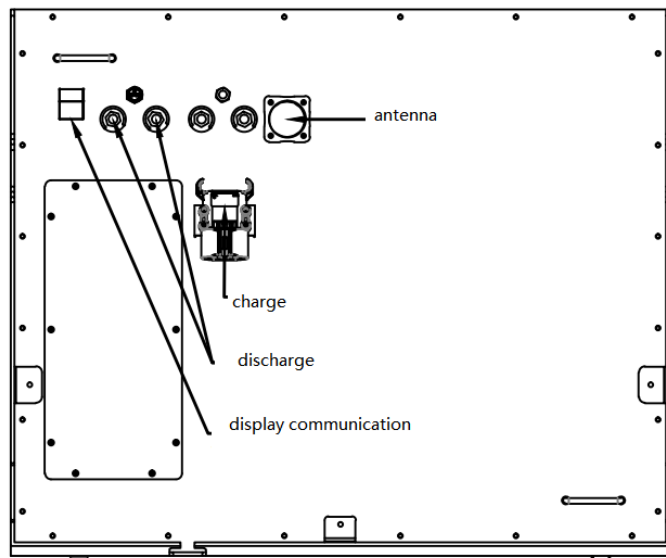

# counter balanced forklift



case vehicle	zoomlionFB30		
battery	QH76. 8V400Ah0322	volt arrange	60V-87. 6V
rated volt	76. 8V	rated capacity	400Ah
discharge current	200A	discharge temperature	-20°C-60°C
charge current	200A	charge temperature	-0°C-45°C
size	1125*900*515mm	weight	1350kg (extra weight included)
communication	CAN, real time monitor	service life	5Y
screen	EV4. 3inch	charge/discharge	separated

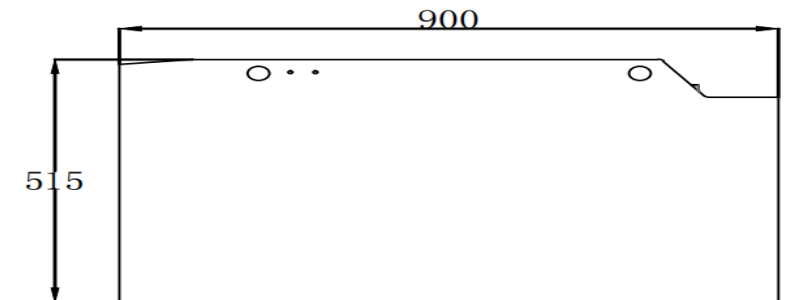
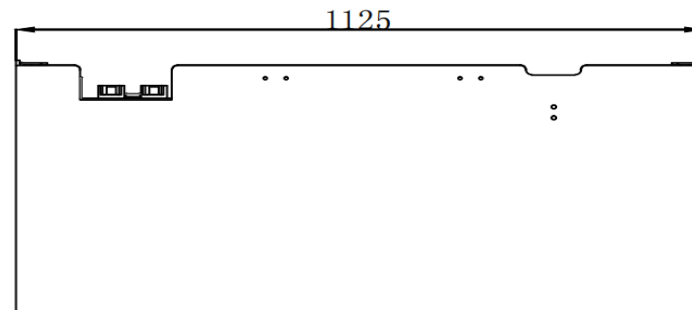
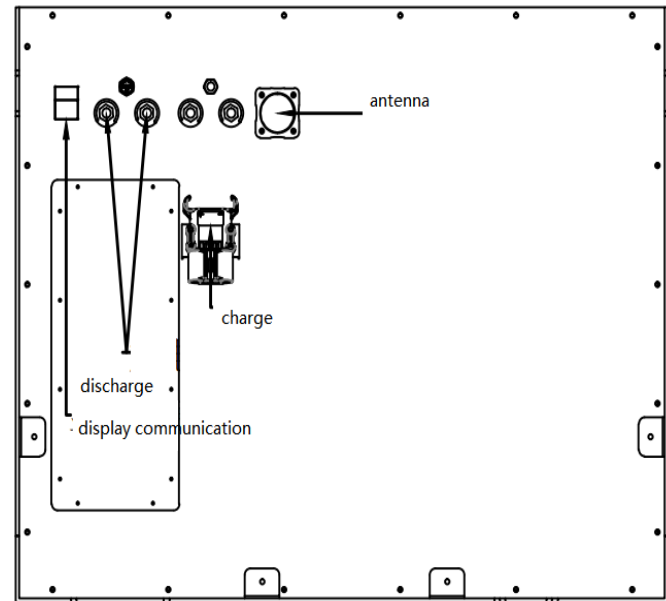
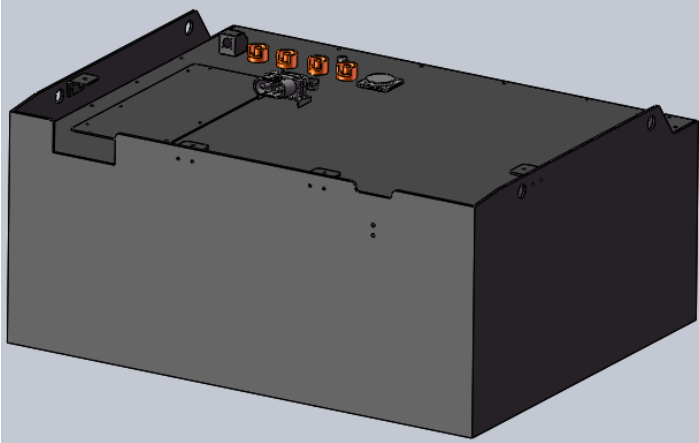

# counter balanced forklift

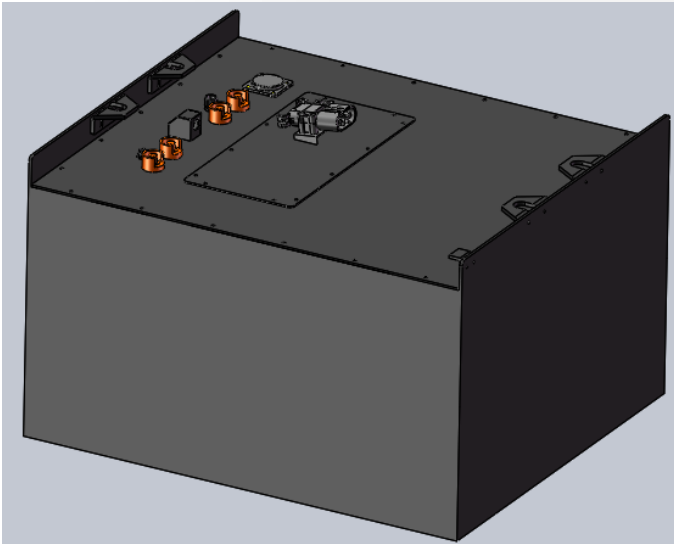

case vehicle	toyota8FBN35		
model	QH83.2V450Ah0404	rated volt	65V-94.9V
rated volt	83.2V	rated capacity	450Ah
discharge current	200A	discharge temperature	-20°C-60°C
charge current	200A	charge temperature	-0°C-45°C
size	948*815*585mm	weight	900kg (extra weight included)
communication	CAN, real time monitor	service life	5Y
screen	EV4.3inch	charge/discharge	separated

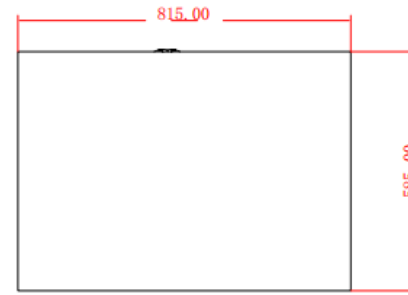
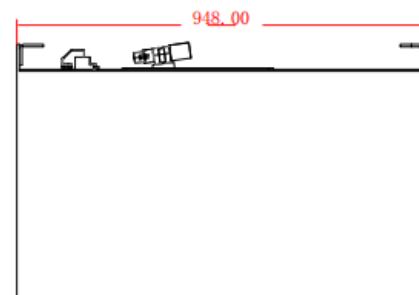
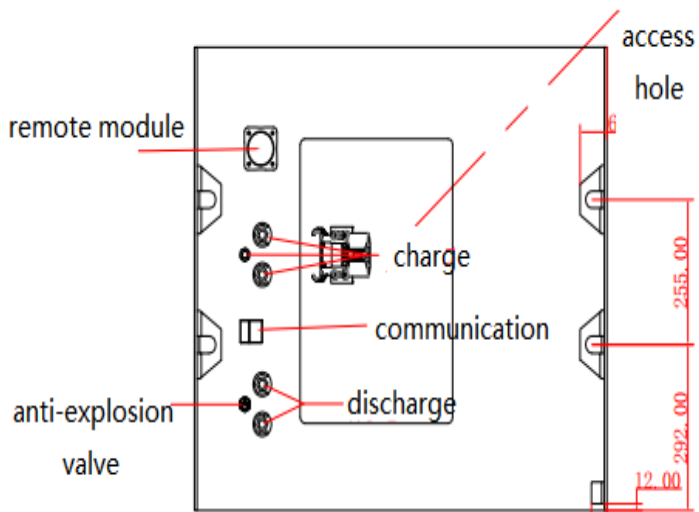

# special vehicle

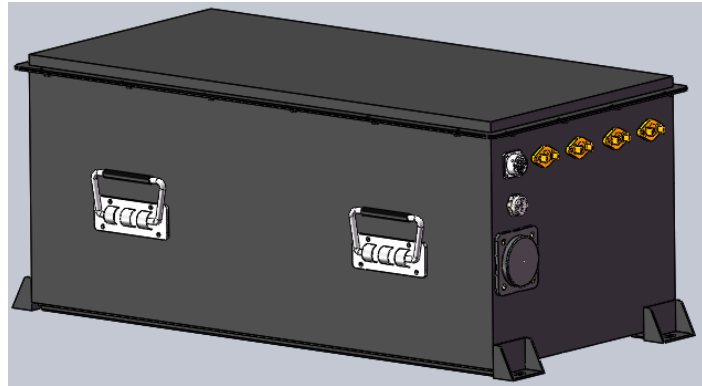

model	QH51.2V200Ah0283	volt arrange	40V-58.4V
rated volt	51.2V	rated capacity	200Ah
discharge current	100A	discharge temperature	-20°C-60°C
charge current	40A	charge temperature	-0°C-45°C
size	735*382*310mm	weight	90kg
communication	CAN, real time monitor	service life	5Y
screen	4.3inch screen	charge/discharge	separated

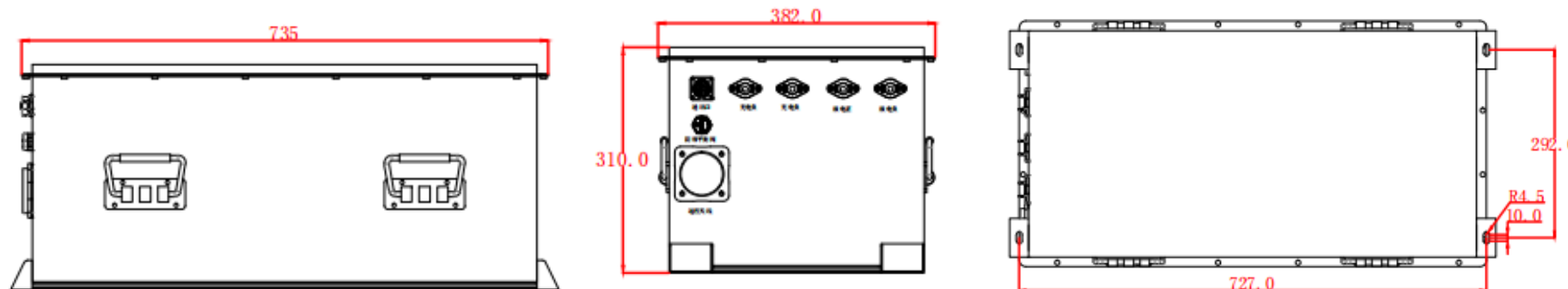
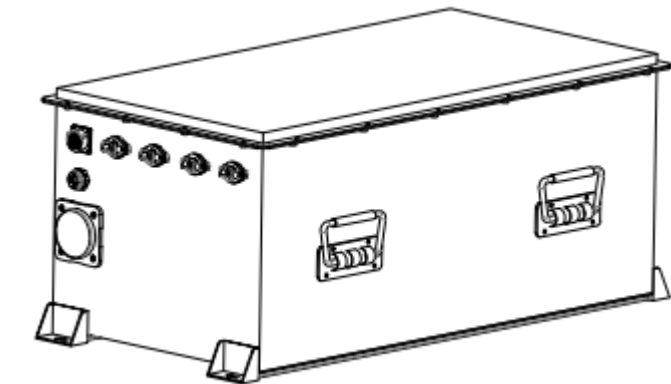

# Special vehicle

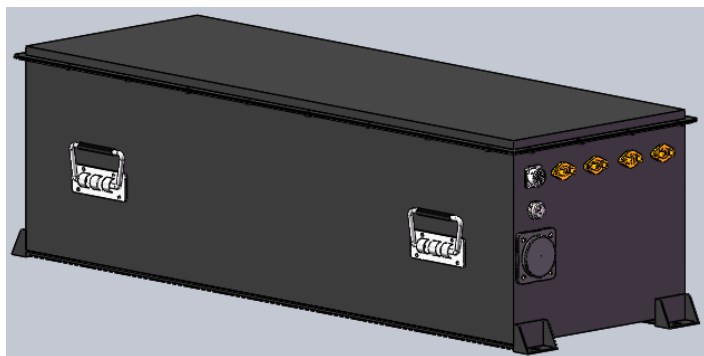

model	QH73. 6V200Ah0264	电压范围	57. 5V-83. 95V
rated volt	73. 6V	rated capacity	200Ah
discharge current	100A	discharge temperature	-20°C-60°C
charge current	40A	charge temperature	-0°C-45°C
size	1077*382*310mm	weight	140kg
communication	CAN, real time monitor	service life	5Y
screen	4.3inch screen	charge/discharge hole	separated

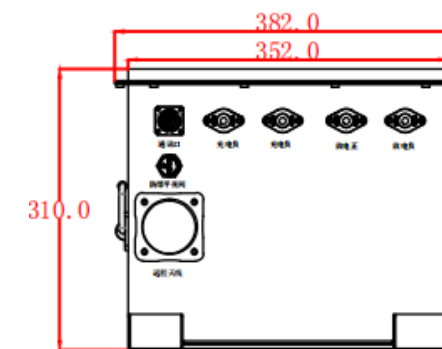
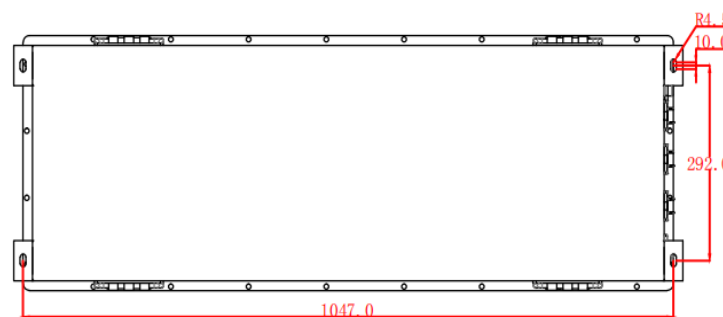
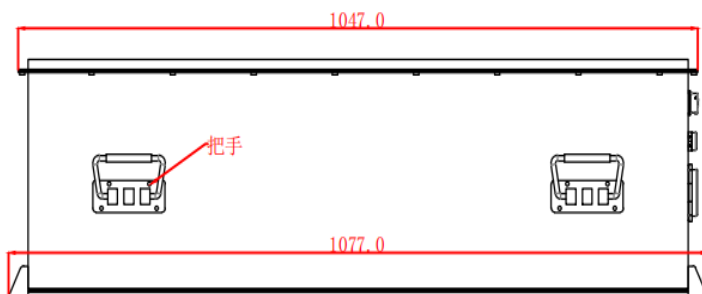

# special vehicles

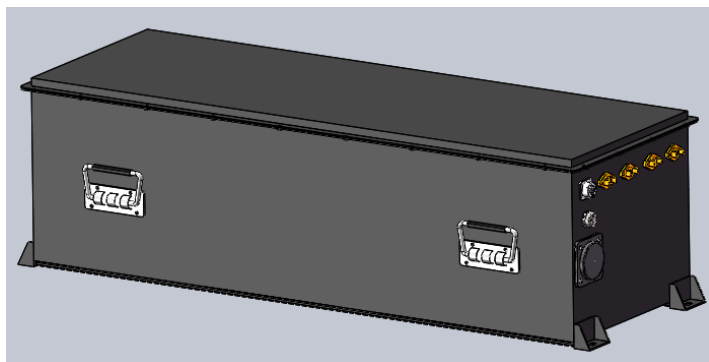

model	QH96V200Ah0435	volt arrange	75V-109.5V
rated volt	96V	rated capacity	200Ah
discharge current	100A	discharge temperature	-20°C-60°C
charge current	40A	charge temperature	-0°C-45°C
size	1240*400*330mm	weight	165kg
communication	CAN, real time monitor	service life	5Y
screen	4.3inch screen	charge/discharge	separated

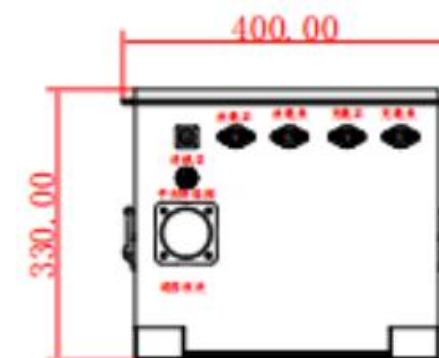
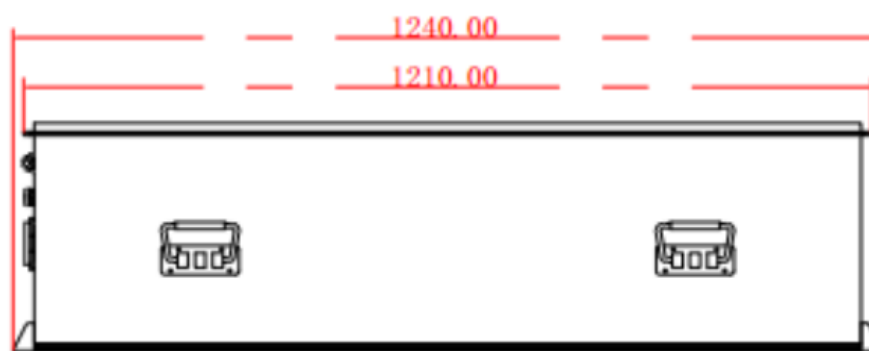
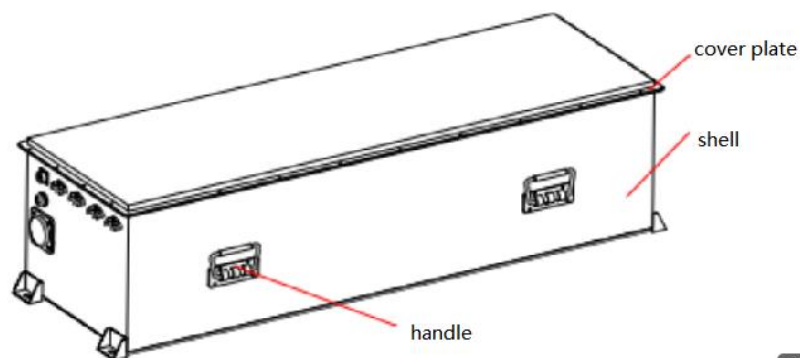



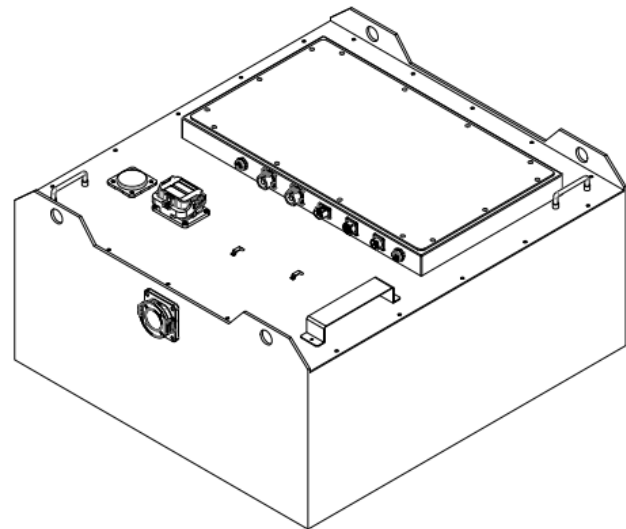
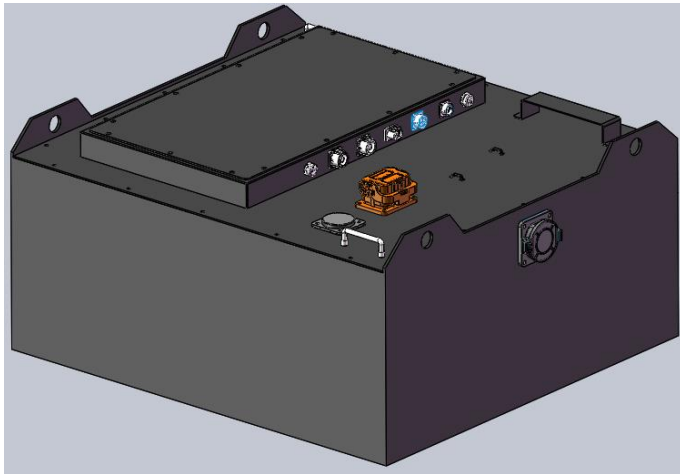

model	QH320V100Ah064	Volt arrange	270V-360V
rated volt	320V	rated capacity	100Ah
discharge current	100A	discharge temperature	-20°C-60°C
charge current	40A	charge temperature	-0°C-45°C
size	910*840*445mm	weight	350kg
communication	CAN, real time monitor	service life	5Y
screen	4.3inch screen	charge/discharge hole	Separated

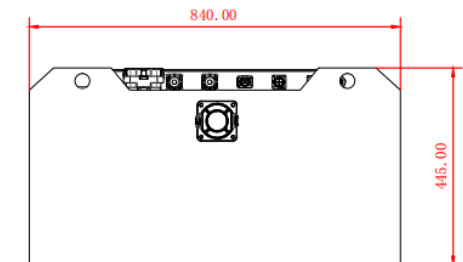
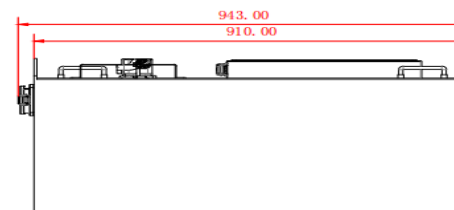
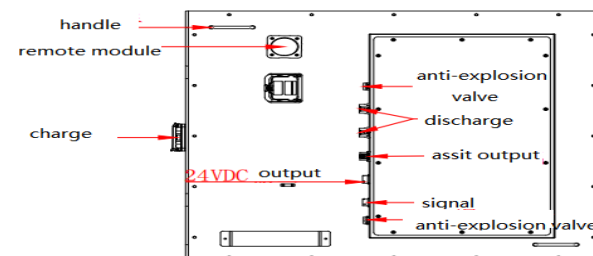

# special vehicles

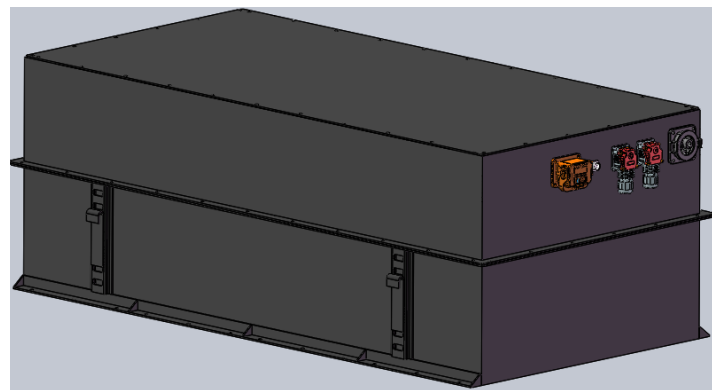

model	QH531.2V150Ah0868	volt arrange	498V-597.6V
rated volt	531.2V	rated capacity	150Ah
discharge current	100A	discharge temperature	-20°C-60°C
charge current	60A	charge temperature	-0°C-45°C
size	1684*845*597mm	weight	750kg
communication	CAN	service life	5Y
screen	4.3inch screen	charge/discharge	separated

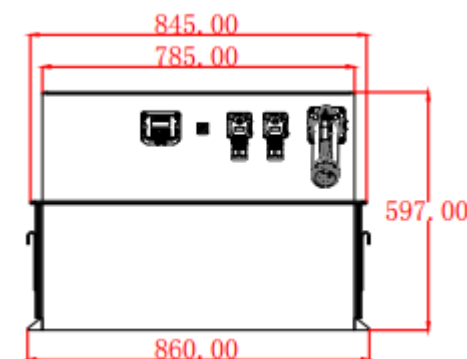
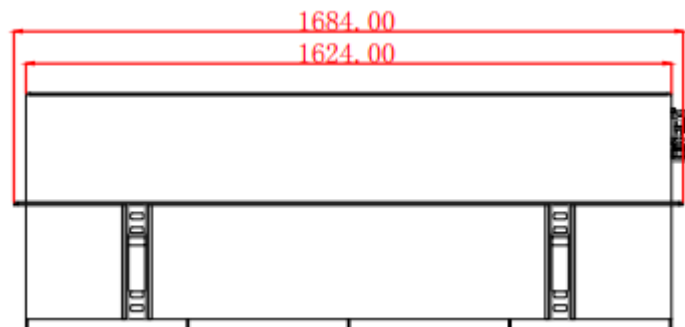
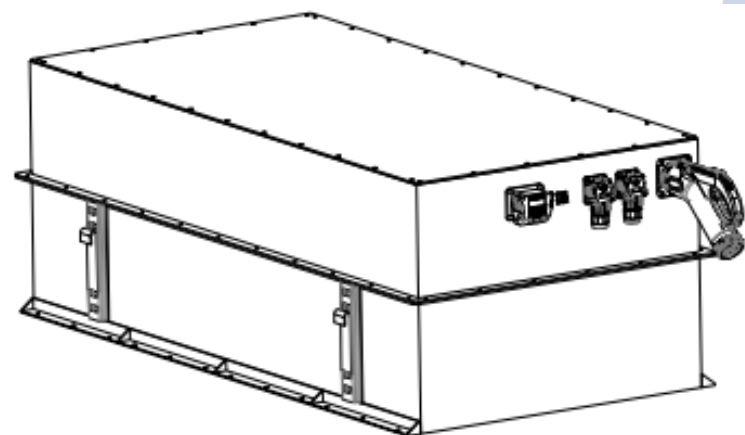



THANK YOU